

# **ST60 Speed Instrument Owner's Handbook**

Document number: 81037-4  
Date: 1st August 2002



---

# Important information

## Safety notices



**WARNING: Product installation & operation**

This equipment must be installed and operated in accordance with the Raymarine instructions provided. Failure to do so could result in personal injury, damage to your boat and/or poor product performance.



**WARNING: Electrical safety**

Make sure you have switched off the power supply before you start installing this product.



**WARNING:**

Although we have designed this product to be accurate and reliable, many factors can affect its performance. Therefore, it should serve only as an aid to navigation and should never replace commonsense and navigational judgement. Always maintain a permanent watch so you can respond to situations as they develop.

## EMC conformance

All Raymarine equipment and accessories are designed to the best industry standards for use in the recreational marine environment.

The design and manufacture of Raymarine equipment and accessories conform to the appropriate Electromagnetic Compatibility (EMC) standards, but correct installation is required to ensure that performance is not compromised.

## Handbook information

To the best of our knowledge, the information in this handbook was correct when it went to press. However, Raymarine cannot accept liability for any inaccuracies or omissions it may contain.

In addition, our policy of continuous product improvement may change specifications without notice. Therefore, Raymarine cannot accept liability for any differences between the product and the handbook.



# Contents

Important information .....	i
Safety notices .....	i
EMC conformance .....	i
Handbook information .....	i
Introduction .....	vii
Data inputs .....	vii
SeaTalk .....	vii
Stand alone operation .....	viii
Remote control .....	viii
Mounting options .....	viii
Parts supplied .....	ix
<b>Chapter 1: Operation .....</b>	<b>1</b>
1.1 Getting started .....	1
Displayed information .....	1
1.2 Normal operation .....	1
Speed information .....	1
Current speed .....	1
Maximum speed .....	2
Average speed .....	2
Velocity made good (to windward) .....	3
Speed over ground .....	3
Log, trip and water temperature .....	3
Log .....	3
Trip .....	4
Water temperature .....	4
Timers .....	4
Race-start timers .....	4
1.3 Display settings .....	6
Illumination .....	6
Contrast .....	6
1.4 Pop-up Pilot .....	6
1.5 Remote control .....	7
<b>Chapter 2: Maintenance and Faultfinding .....</b>	<b>9</b>
2.1 Maintenance .....	9
Servicing and safety .....	9
Instrument .....	9
Transducer .....	9
Cabling .....	10
2.2 Fault finding .....	10
Preliminary procedures .....	10

	Fixing faults .....	10
	Technical support .....	11
	World wide web .....	11
	Telephone help line .....	11
	Help us to help you .....	11
<b>Chapter 3:</b>	<b>Installation .....</b>	<b>13</b>
3.1	Planning your installation .....	13
	Site requirements .....	13
	Transducer .....	13
	Instrument .....	15
	EMC Installation Guidelines .....	16
	Suppression Ferrites .....	17
	Connections to Other Equipment .....	17
3.2	Procedures .....	17
	Unpacking .....	17
	Fitting the instrument .....	18
	Surface mounting .....	18
	Flush mounting .....	19
	Bracket mounting .....	22
	Fitting transducer .....	22
	Running transducer cable .....	22
	Connecting the instrument .....	23
	Types of connection .....	23
	Signal connections .....	24
	Power supply connections .....	24
<b>Chapter 4:</b>	<b>Calibration .....</b>	<b>27</b>
4.1	Introduction .....	27
	EMC conformance .....	27
	Speed readings .....	27
4.2	User calibration .....	28
	Procedure .....	28
	Set speed units .....	28
	Set resolution .....	28
	Set log units .....	28
	Setting the correct speed .....	28
	Set temperature units .....	29
	Temperature calibration .....	29
	Timer buzzer .....	29
	Pop-up pilot .....	32
	Leaving User calibration .....	32

---

4.3	Intermediate calibration .....	32
	Speed calibration .....	33
	Leaving Intermediate calibration .....	36
4.4	Dealer calibration .....	36
	User calibration on/off .....	36
	Response settings .....	38
	Boat show mode .....	38
	Factory defaults .....	38
	Leaving Dealer calibration .....	38





## Introduction

Thank you for purchasing a Raymarine product. We are sure your ST60 instrument will give you many years of trouble-free operation.

This handbook describes how to install and use the Raymarine ST60 Speed instrument. This instrument provides accurate speed, log, trip and timer information, on a high quality Liquid Crystal Display (LCD). The instrument is constructed in a rugged weather-proofed case to provide reliable performance, even under the most demanding conditions.

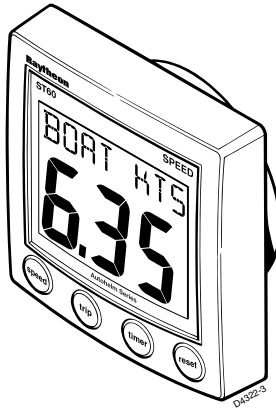

## Data inputs

The ST60 Speed instrument receives data either from an appropriate speed transducer and/or from a SeaTalk instrumentation system.

## SeaTalk

SeaTalk enables a number of compatible instruments to operate as a single, integrated navigational system. Instruments in a SeaTalk system are linked by means of a single cable, which feeds both power and data. Instruments can therefore be added to the system by plugging them into the network. SeaTalk is flexible enough to adapt to any number of compatible instruments without requiring a central processor. SeaTalk can also communicate via an interface, with non-SeaTalk equipment using the internationally-accepted National Marine Electronics Association (NMEA) protocol.

In a SeaTalk system, each instrument can be either a master or dedicated repeater unit. A master instrument is directly connected to a transducer (the device that provides the raw data), and provides data and control for the service it is providing, to all other equipment on the SeaTalk network. A slave instrument is not directly connected to a transducer but repeats information provided by other equipment in the SeaTalk network.

The ST60 Speed instrument can fulfil both master and repeater roles.

## **Stand alone operation**

In Stand alone operation, the ST60 Speed instrument is connected only to the relevant transducer and does not display information from, or provide information to, any other instruments.

## **Remote control**

When connected to SeaTalk, the ST60 Speed instrument can be controlled remotely by a SeaTalk Remote Keypad Unit, to provide instant remote access to the various display readouts.

## **Mounting options**

If you do not want to surface mount your ST60 instrument, options are available for:

- Flush mounting. If you have ordered the flush mounting option a low-profile bezel and four fixing screws are also provided.
- Bracket mounting.

---

## Parts supplied

Unpack your ST60 instrument and check that the following items are present:

- Item 1, ST60 Speed instrument fitted with standard bezel for surface mounting.
- Item 2, Fixing studs (2).
- Item 3, Thumb nuts (2).
- Item 4, Gasket.
- Item 5, Speed transducer, plus bung (not illustrated).
- Item 6, SeaTalk interconnection cable.
- Item 7, Power cable.
- Item 8, Instrument Cover.
- Item 9, Owner's Handbook. A Warranty document and fitting templates are included in this Handbook.
- Item 10, Cue Card.

Spare spade terminals are also provided, to re-terminate the transducer cable if it has to be cut to facilitate installation.

**Note:** *The above packing list is for an ST60 Speed system. Where an instrument is purchased separately, a transducer is not included.*



# Chapter 1: Operation

## 1.1 Getting started

### Displayed information

Your ST60 Speed instrument provides the following:

- Speed information.
- Log, trip and water temperature information.
- Count-up and race-start timers.

#### **CAUTION: Calibration requirement**

The ST60 Speed instrument is calibrated to default settings when supplied. To ensure optimum performance on your boat, this product **MUST** be calibrated before use. Do **NOT** use the product until it has been calibrated using the procedures in Chapter 4, Calibration.

## 1.2 Normal operation

Use the flow charts in this Chapter to operate your ST60 Speed instrument. The flow charts show the sequence of key presses and displays for the various operating tasks. All key presses are momentary unless otherwise stated.

### Speed information

The **speed** key gives access to current speed, maximum speed, average speed, velocity made good (VMG) and speed over ground (SOG) information. Refer to the *Using speed key* flow diagram to access the information you want.

#### **Current speed**

Speed measurement units can be either knots (KTS), miles per hour (MPH) or kilometres per hour (KMH). The required units are selected during user calibration (see *Chapter 4, Calibration*).

### Maximum speed

The maximum speed is reset at power up. It can also be reset manually by pressing the **reset** key for 3 seconds. The display shows the maximum recorded speed since the last reset. This screen times-out to current speed if no user action occurs for 7 seconds.

### Average speed

The average speed is reset at power up. It can also be reset manually by pressing the **reset** key for 3 seconds. The display shows the average speed calculated since the last reset. This screen times-out to current speed if no user action occurs for 7 seconds.

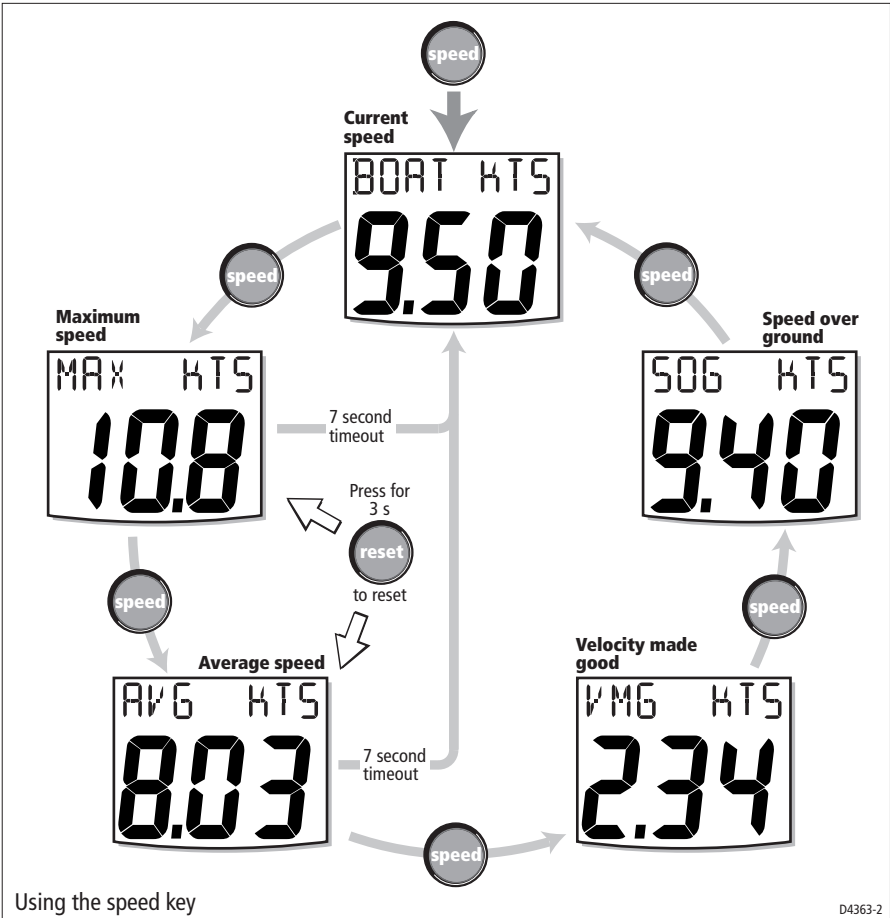

## Velocity made good (to windward)

Velocity made good (VMG) information is available if your ST60 Speed instrument is part of a SeaTalk system to which a SeaTalk-compatible wind instrument is also connected.

## Speed over ground

Speed over ground (SOG) information is available if your ST60 Speed instrument is part of a SeaTalk system to which a suitable GPS is also connected.

## Log, trip and water temperature

The **trip** key gives access to log, trip and water temperature information. Refer to the *Using trip key* flow diagram to access the information you want.

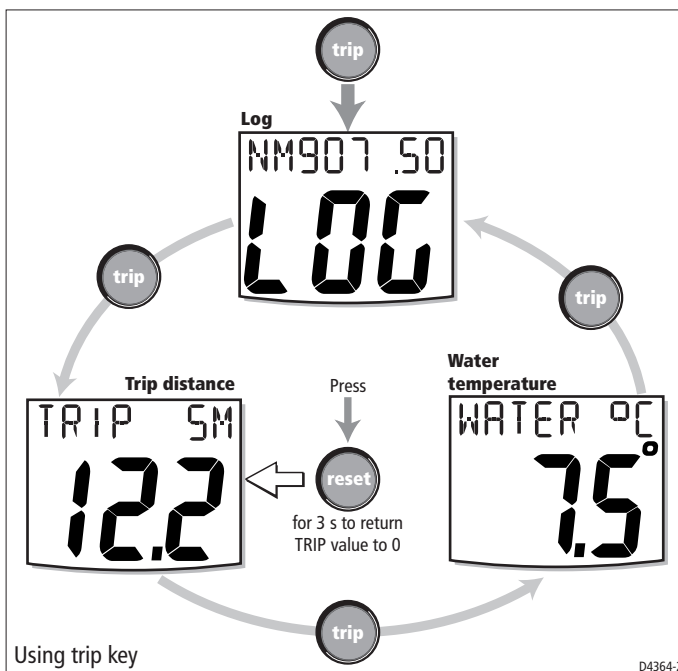

### Log

The Log screen shows the total distance covered by the vessel since the ST60 Speed instrument was fitted.

## Trip

The trip distance is reset at power up and may also be reset manually, by pressing the **reset** key for 3 seconds. The display shows the distance covered since the last reset.

**Note:** *The trip distance can be reset only if the instrument is a master, i.e. connected to a speed transducer.*

## Water temperature

The water temperature is shown in either degrees Celsius or Fahrenheit, as set during calibration (see *Chapter 4, Calibration*).

## Timers

The **timer** key gives access to a count-up timer and to two race-start timers. Times are either in seconds (S) or minutes (M), depending on the counter values.

Refer to the *Using timer key* flow diagram to display the required timer. Once you have selected the required timer display, press the **reset** key to start the timer running. When a timer is running, the delimiter (i.e. '.' or ':') flashes. For lap timing, press the **reset** key. To stop and reset a timer to the start value, hold down the **reset** key for 1 second.

Once a timer is running, you can leave the timer page and select any other display. The counter will continue to run in the background.

## Race-start timers

You can set each race-start timer to any whole-minute value from 1 to 15 minutes.

**Note:** *When the instrument is first installed, the race-start timers are set to 4 and 5 minutes respectively.*

To set a race-start timer:

1. Use the **timer** key as shown in the *Using timer key* flow diagram to select the required race-start timer.
2. Simultaneously press the **timer** and **reset** keys to enter the race-start timer adjust mode.
3. Use either the **timer** or **reset** key to set the required value.
4. Simultaneously press the **timer** and **reset** keys to save the value and leave the race-start timer adjust mode



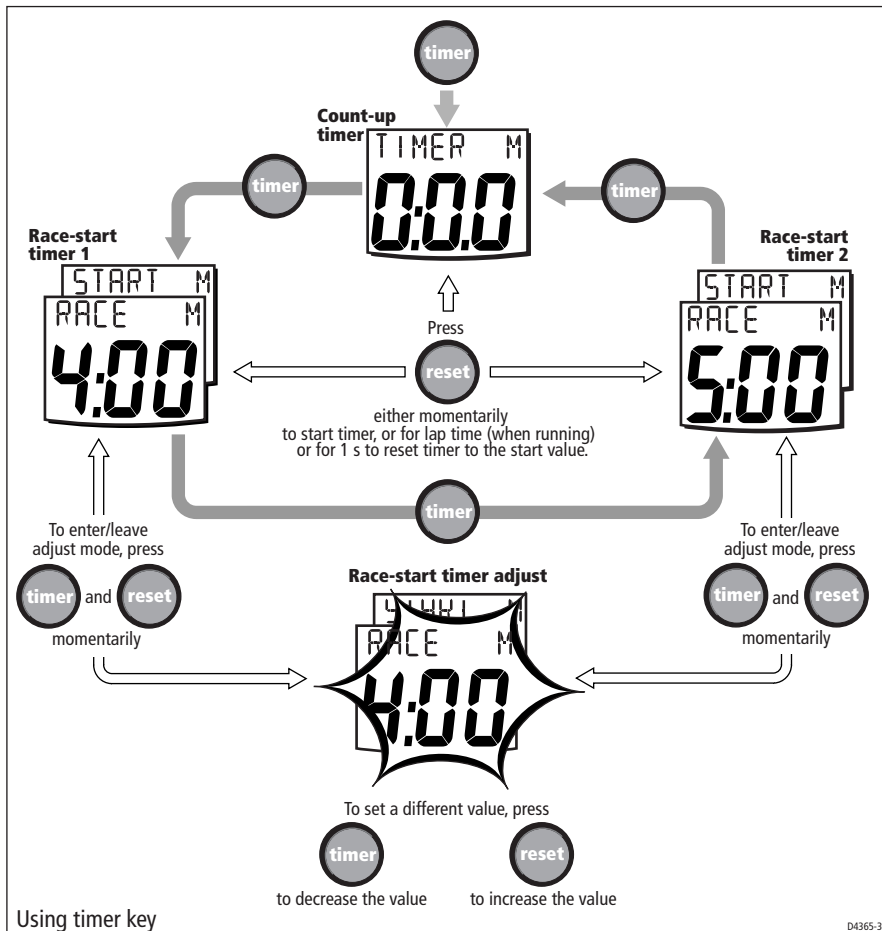

If you are using one of the race-start timers and the timer buzzer is enabled, the buzzer will:

- Double-beep every minute.
- Beep three times at the start of the last 30 seconds.
- Beep once for each of the last 10 seconds.
- Beep for 2 seconds at zero.

The timer buzzer is enabled or disabled as part of the calibration procedure (see *Chapter 4, Calibration*).

**Note:** After a race-start timer has counted-down to zero, it will then start counting up.

## 1.3 Display settings

### Illumination

When the instrument is first powered up, the display illumination is set to its lowest (courtesy) level to facilitate initial access to the keys. To adjust the level of illumination:

1. Hold down the speed key for approximately one second, to enter the illumination-adjust mode.
2. There are four preset illumination levels. Press the **speed** key to cycle through the these levels until you reach the level you want.
3. Press any other key to leave the illumination-adjust mode.

**Note:** *The display will time out to normal operation 7 seconds after the last key press.*

### Contrast

To adjust the display contrast:

1. Hold down the **speed** key for approximately two seconds, to enter the contrast-adjust mode.
2. There are four preset contrast settings. Press the **speed** key to cycle through the these settings until you achieve optimum display quality.
3. Press any other key to leave the contrast-adjust mode.

**Note:** *The display will time out to normal operation 7 seconds after the last key press.*

## 1.4 Pop-up Pilot

A Pop-up Pilot facility enables instruments connected to SeaTalk to constantly monitor any changes to the autopilot mode and to the course settings. If one of these parameters changes, the new value is immediately displayed on the ST60 instrument for 5 seconds, after which time the display reverts to the previous display.

This facility can be enabled or disabled during User calibration (see *Chapter 4, Calibration*).

## 1.5 Remote control

When it is connected to SeaTalk, the ST60 Speed instrument can be controlled remotely with a SeaTalk Remote Keypad Unit. Remote control of an instrument is indicated by a REMOTE legend on the display, to indicate that the keypad has control.

Details on how to use the remote control facility can be found in the *SeaTalk Remote Keypad Owner's Handbook*.



# Chapter 2: Maintenance and Faultfinding

## 2.1 Maintenance

### Servicing and safety

- Raymarine equipment should be serviced only by authorised Raymarine service technicians. They will ensure that servicing procedures and replacement parts used will not affect performance. There are no user-serviceable parts in any Raymarine product.
- Some products generate high voltages, and so never handle the cables/connectors when power is being applied to the equipment.
- When powered up, all electrical equipment produces electromagnetic fields. These can cause adjacent pieces of electrical equipment to interact with one another, with a consequent adverse effect on operation. In order to minimise these effects and enable you to get the best possible performance from your Raymarine equipment, guidelines are given in the installation instructions, to enable you to ensure minimum interaction between different items of equipment, i.e. ensure optimum Electromagnetic Compatibility (EMC).
- Always report any EMC-related problem to your nearest Raymarine dealer. We use such information to improve our quality standards.
- In some installations, it may not be possible to prevent the equipment from being affected by external influences. In general this will not damage the equipment but it can lead to spurious resetting action, or momentarily may result in faulty operation.

### Instrument

Certain atmospheric conditions may cause condensation to form on the instrument window. This will not harm the instrument and can be cleared by increasing the illumination setting to Level 3.

Periodically clean your ST60 instrument with a soft damp cloth. Do NOT use chemical and abrasive materials to clean the instrument.

### Transducer

Refer to the Installation and Maintenance instructions supplied with the transducer.

## Cabling

Examine all cables for chafing or other damage to the outer shield and, where necessary, replace and re-secure.

## 2.2 Fault finding

### Preliminary procedures

Changes in the electronic environment may adversely affect the operation of your ST60 equipment. Typical examples of such changes are:

- Electrical equipment has recently been installed or moved aboard your vessel.
- You are in the vicinity of another vessel or shore station emitting radio signals.

If you appear to have a problem, first ensure that the EMC requirements are still being met before further investigating the problem.

### Fixing faults

All Raymarine products are subjected to comprehensive test and quality assurance programmes prior to packing and shipping. However, if a fault occurs, the following table may help to identify and rectify the problem.

<b>Fault</b>	<b>Cause</b>	<b>Remedy</b>
Display blank	No power supply	Check power supply. Check SeaTalk cabling and connector security Check fuse/circuit breaker
No transfer of information between SeaTalk instruments (e.g. illumination levels).	SeaTalk cable or connector fault	Check security of SeaTalk connectors. Check condition of SeaTalk cables. Isolate faulty instrument by disconnecting instruments one by one.
Failure of a group of SeaTalk instruments.	SeaTalk cable or connector fault	Check the security of SeaTalk connectors between functioning and non-functioning instruments
No speed or temperature information	Transducer cable or connector fault	Check the condition of the transducer cable and the security of the connections
No speed information. Temperature available.	Transducer paddle wheel fouled	Clean paddle wheel. See CAUTION below

**CAUTION:**

**If you need to remove the transducer insert, have the transducer bung to hand and secure it in the transducer body immediately after the insert has been removed, to prevent excessive ingress of water.**

## Technical support

Raymarine provides a comprehensive customer support service, on the world wide web and by telephone help line. Please use either of these facilities if you are unable to rectify a problem.

### World wide web

Please visit the Customer Support area of our web site at:

**[www.raymarine.com](http://www.raymarine.com)**

As well as providing a comprehensive Frequently Asked Questions section and servicing information, it also gives e-mail access to the Raymarine Technical Support Department and a details of the locations of Raymarine agents, worldwide.

### Telephone help line

If you do not have access to the world wide web, please call:

1-800-539-5539, extension 2444 or  
(603) 881-5200 extension 2444

### Help us to help you

When requesting service, please quote the following product information:

- Equipment type.
- Model number.
- Serial number.
- Software issue number.

The Software issue number can be ascertained by means of the Intermediate Calibration facility, see *Chapter 4, Calibration*.





## Chapter 3: Installation

This chapter describes how to install the ST60 Speed instrument, and associated speed transducer. The transducer is fitted in the hull of the vessel and is connected to the rear of the instrument. The actual type of transducer depends on the type of hull in which it is to be installed.

For advice, or further information regarding the installation of this equipment, please contact the Raymarine Product Support Department or your own National Distributor.

### 3.1 Planning your installation

Before starting the installation, spend some time considering the best positions for both transducer and instrument, such that the *Site Requirements* and the *EMC Guidelines* (below) are satisfied.

#### Site requirements

##### Transducer

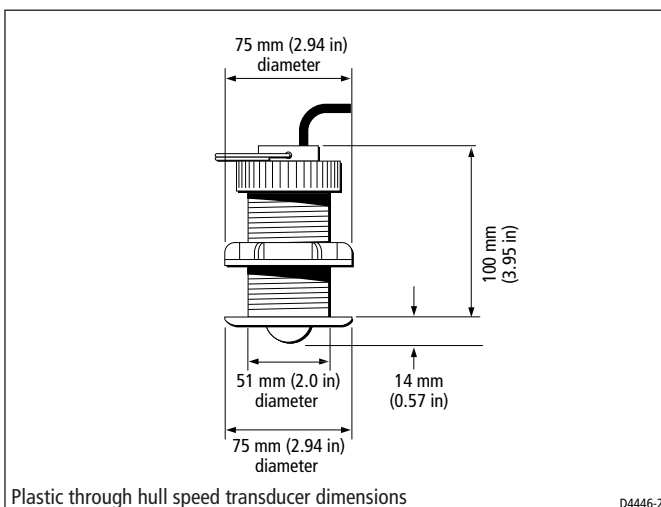

The transducer types required for the various hull types are as follows:

Hull material	Transducer type
Glass reinforced plastic (GRP)	M78712 Through hull plastic
Steel	M78712 Through hull plastic
Aluminium	M78712 Through hull plastic
Wood	M78716 Through hull bronze

Other transducer types are also available for specific requirements. For further details, contact your local Raymarine dealer.

For accurate speed readings the transducer should be sited within the clear water flow areas indicated by the shaded areas in the following diagram.

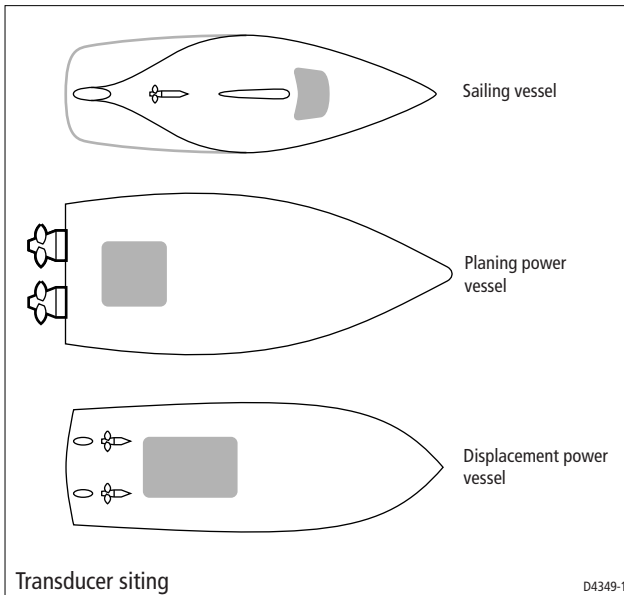

The transducer should also:

- Be ahead of the propellers (by a minimum of 10% of the water line length).
- Be at least 150 mm (6 in) away from the keel (ideally ahead of the keel if a sailing yacht).
- Be as near as possible to the centre line of the vessel.

- Be clear of other through-hull fittings or projections.
- Have sufficient clearance inside the hull to fit the nut.
- Have 100 mm (4 in) of headroom to allow for withdrawal.

There must also be a viable route for the transducer cable to be routed to the instrument.

### Instrument

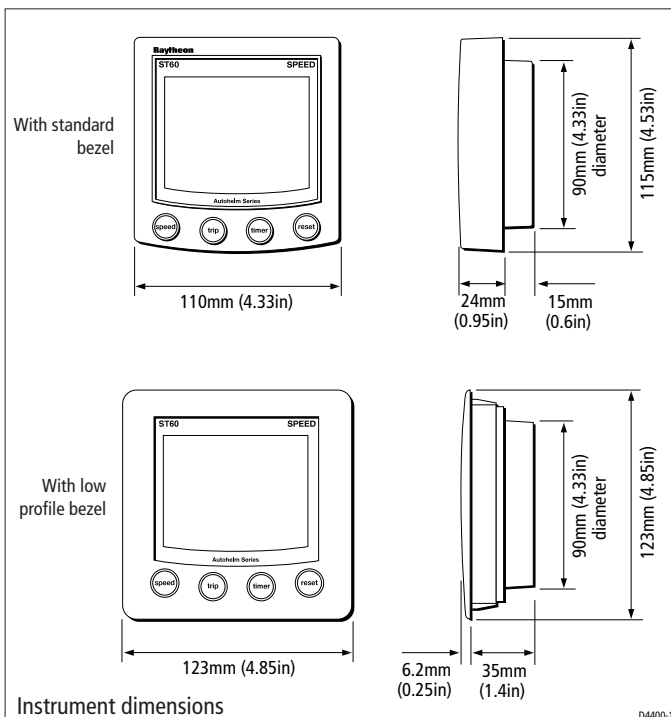

### CAUTION:

**The presence of moisture at the rear of the instrument could cause damage either by entering the instrument through the breathing hole or by coming into contact with the electrical connectors.**

ST60 instruments can be fitted either above or below deck, provided the rear of the instrument is sited where it is protected from contact with water.

Each instrument must also be positioned where:

- It is easily read by the helmsman
- It is protected against physical damage
- It is at least 230 mm (9 in) from a compass
- It is at least 500 mm (20 in) from radio receiving equipment
- There is reasonable rear access for installation and servicing

## EMC Installation Guidelines

All Raymarine equipment and accessories are designed to the best industry standards for use in the recreational marine environment.

Their design and manufacture conforms to the appropriate Electromagnetic Compatibility (EMC) standards, but correct installation is required to ensure that performance is not compromised. Although every effort has been taken to ensure that they will perform under all conditions, it is important to understand what factors could affect the operation of the product.

The guidelines given here describe the conditions for optimum EMC performance, but it is recognized that it may not be possible to meet all of these conditions in all situations. To ensure the best possible conditions for EMC performance within the constraints imposed by any location, always ensure the maximum separation possible between different items of electrical equipment.

For **optimum** EMC performance, it is recommended that **wherever possible**:

- Raymarine equipment and cables connected to it are:
  - At least 3 ft (1 m) from any equipment transmitting or cables carrying radio signals e.g. VHF radios, cables and antennas. In the case of SSB radios, the distance should be increased to 7 ft (2 m).
  - More than 7 ft (2 m) from the path of a radar beam. A radar beam can normally be assumed to spread 20 degrees above and below the radiating element.
- The equipment is supplied from a separate battery from that used for engine start. Voltage drops below 10 V in the power supply to our products, and starter motor transients, can cause the equipment to reset. This will not damage the equipment, but may cause the loss of some information and may change the operating mode.

- Raymarine specified cables are used. Cutting and rejoining these cables can compromise EMC performance and must be avoided unless doing so is detailed in the installation manual.
- If a suppression ferrite is attached to a cable, this ferrite should not be removed. If the ferrite needs to be removed during installation it must be reassembled in the same position.

### Suppression Ferrites

The following illustration shows typical cable suppression ferrites used with Raymarine equipment. Always use the ferrites supplied by Raymarine.

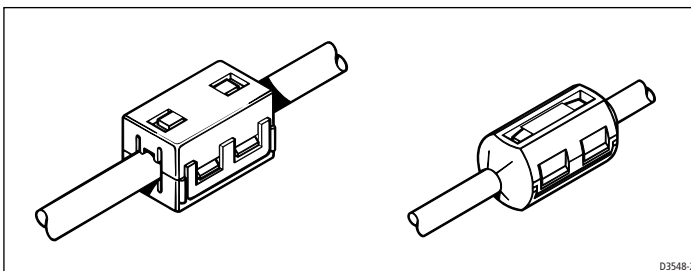

### Connections to Other Equipment

If your Raymarine equipment is to be connected to other equipment using a cable not supplied by Raymarine, a suppression ferrite **MUST** always be attached to the cable near the Raymarine unit.

## 3.2 Procedures

As it is not possible to describe procedures for all possible installation scenarios, the procedures given here describe the broad requirements for installing Speed transducers and the ST60 Speed instrument. Adapt these procedures as appropriate, to suit your individual requirement.

#### **CAUTION:**

**Where it is necessary to cut holes (e.g. for cable routing and instrument mounting), ensure that these will not cause a hazard by weakening critical parts of the vessel's structure.**

### Unpacking

Unpack your ST60 equipment and check that the items described in *Introduction* are present.

Each ST60 instrument is supplied with a standard bezel for surface mounting. Optional mounting kits are available for flush mounting and bracket mounting the instrument. If you have ordered the flush mounting option a low-profile bezel and four fixing screws are also provided.

## Fitting the instrument

The ST60 Speed instrument can be installed using one of a number of different mounting options:

- Surface mounting. Gives a profile of approximately 24 mm.
- Flush mounting. Gives a profile of approximately 6 mm.
- Bracket mounting.

The ST60 instruments can also be mounted behind a panel with just the instrument dial and keys visible.

### Surface mounting

To surface mount your ST60 instrument (see the *Surface mounting* illustration):

1. Ensure that:
  - The selected location is clean, smooth and flat.
  - There is sufficient space behind the selected location to accommodate the rear of the instrument and connectors.

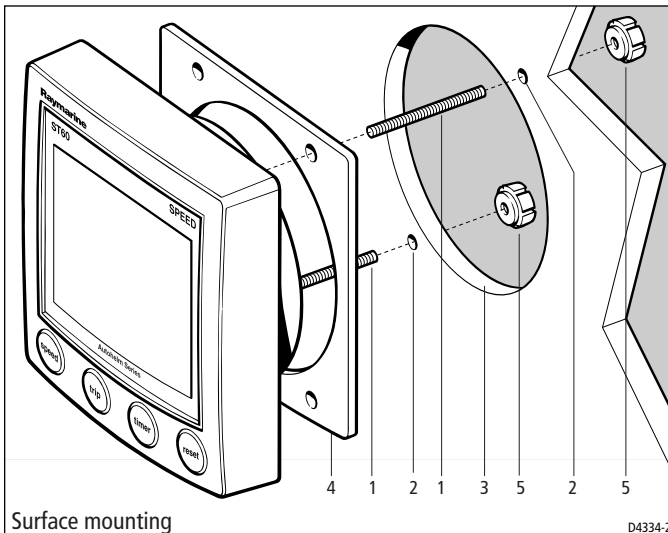

2. Apply the surface mount template (supplied at the rear of this handbook) to the selected location and mark the centres for the fixing studs (1) and the aperture (3) that will take the rear casing of the instrument.
3. Drill out the two 5 mm fixing stud clearance holes (2).
4. Cut out the clearance hole (3) then remove the template.
5. Peel off the protective sheet from the self-adhesive gasket (4) then stick the gasket into position on the rear of the instrument.
6. Screw the two fixing studs into the threaded sockets on the rear of the instrument.
7. Mount the assembled instrument, studs, bezel and gasket into the panel. Secure from behind with the thumb nuts (5).

## Flush mounting

The Flush Mounting Kit uses a low-profile bezel to reduce the fitted profile of the instrument, to approximately 6 mm above the panel fascia.

### Fitting the low-profile bezel

In order to flush-mount your ST60 instrument, you must first replace the standard bezel with the low-profile bezel as follows:

1. Hold the instrument in both hands with the display towards you.

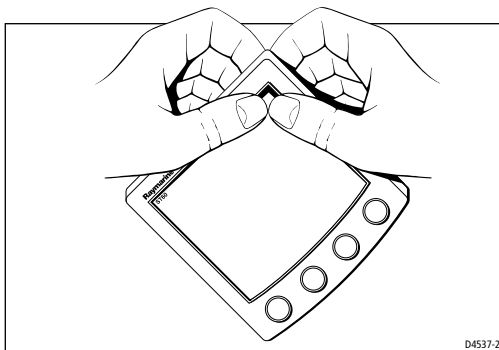

2. Using both thumbs, gently press an upper corner of the instrument from the bezel, then remove the bezel from the instrument. Retain the rubber keypad which is released when the bezel is removed.
3. Referring to the *Fitting the low-profile bezel* illustration, place the instrument face upwards on a flat surface and place the rubber keypad (7) in position around the display window (i.e. so that each key outline is located over its associated key on the instrument).

4. Snap the low-profile bezel (8) in position over the instrument, so that the rubber keys are correctly located in the holes on the bezel.

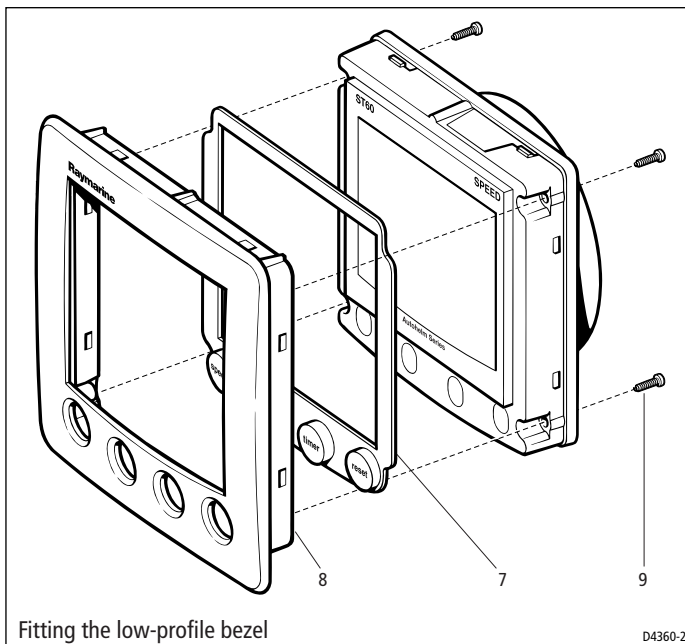
**CAUTION:**

It is essential that only screws of the correct size are used to secure the instrument to the bezel. Failure to observe this caution could result in damage to both the instrument and the bezel.

5. Using the four, self-tapping screws (9) provided, secure the instrument and bezel together. Fit the screws from the rear of the instrument and tighten them sufficiently to secure the instrument and bezel together. **DO NOT OVERTIGHTEN.**

**Flush mounting procedure**

Flush mount your instrument (see the *Flush mounting* illustration) as follows:

1. Assemble the ST60 instrument and low-profile bezel as described under *Fitting the low-profile bezel*.



2. Ensure that:
  - The panel on which you intend to mount the instrument is between 3 mm and 20 mm thickness.
  - The selected location is clean, smooth and flat.
  - There is sufficient space behind the selected location to accommodate the rear of the instrument and connectors.
3. Apply the flush mount template (supplied at the rear of this handbook) to the selected location and mark out the aperture into which the assembled instrument and bezel will sit.
4. Cut out the aperture (3) for the assembled instrument and bezel and remove the template.
5. Peel off the protective sheet from the self-adhesive gasket (4) then stick the gasket into position on the rear of the bezel.

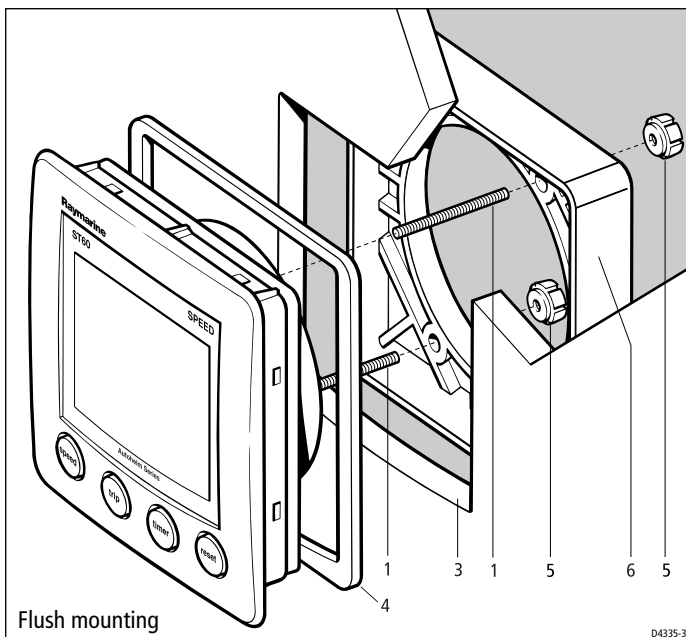

6. Screw the two fixing studs (1) into the threaded sockets on the rear of the instrument.
7. Mount the assembled instrument, studs, bezel and gasket into the panel.
8. Locate the flush mount bracket (6) onto the fixing studs and secure the assembly to the panel with the thumb-nuts (5).

## Bracket mounting

A Control Unit Mounting Bracket (Part No. E25009) enables you to mount your ST60 instrument in locations where other forms of mounting are impractical. Although this provides a useful alternative method for securing your instrument, it is only suitable for use in positions where the instrument will not be exposed to water.

To bracket mount your ST60 instrument, do so in accordance with the Control Unit Mounting Bracket *Instruction Sheet*.

## Fitting transducer

The ST60 Speed instrument is supplied, with a through-hull Speed transducer.

The Speed transducer is supplied with detailed instructions for installation and maintenance. Before attempting to install the Speed transducer, read these instructions and the *Site requirements* for transducers described in this Chapter.

Once you are satisfied you can meet all the installation requirements, install the transducer in accordance with the accompanying installation instructions.

## Running transducer cable

Each transducer type has a 14 m (45 ft) cable fitted with spade terminals for connection to the ST60 Speed instrument. The manner in which you run the cable will depend on the locations of the transducer and instrument.

Observing the following guidelines, run the transducer cable to the ST60 Speed instrument:

- If the cable has to be fed through the deck, always use a proprietary deck gland.
- Where cables are fed through holes, always use grommets to prevent chafing.
- Secure long cable runs so they do not present a hazard.
- Do not route the cable through bilges.
- Wherever possible, route the cable away from fluorescent lights, engines, radio transmitting equipment, as these may cause interference.

- The transducer cable is fitted with spade connectors for direct connection to the rear of the instrument. However, it may be necessary to remove these to facilitate installation, e.g. if the cable has to be routed through narrow apertures. Extra spade connectors are provided, to replace any that are removed when running the cable. When fitting spade connectors, prepare the cable as at (a) in the following illustration, then fold back the wire strands and insert into the spade connector as at (b). Ensure the wire strands do not extend beyond the rear of the spade connector insulation, then crimp the connector to the wire.

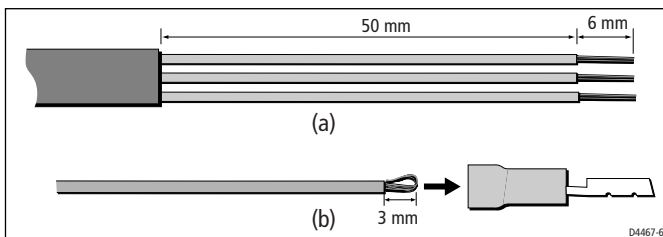

## Connecting the instrument

### Types of connection

The ST60 Speed instrument, can be connected:

- As a stand-alone, master instrument connected directly to the Speed transducer.
- As a SeaTalk repeater.
- To fulfil both repeater and master roles by being connected both to the transducer and to SeaTalk.

If instruments are connected to SeaTalk, no separate power connection is necessary. Where a SeaTalk system includes an autopilot, the power for the system is provided by the autopilot.

A range of Raymarine SeaTalk extension cables is available to connect separated instruments. These cables are supplied with a SeaTalk connector fitted to each end. A junction box can be used to join cables.

## Signal connections

Make the necessary connections to your ST60 instrument (see the *Connection to ST60 Speed instrument* illustration).

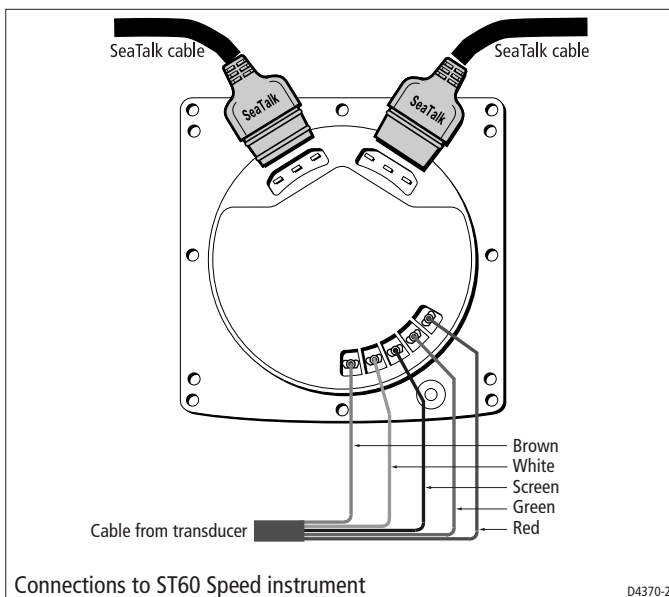

## Power supply connections

### SeaTalk systems

#### **CAUTION:**

**When instruments are connected to SeaTalk, ensure that the power supply for the SeaTalk 12 V line is protected by a 5 A fuse.**

Systems with a large number of instruments on the SeaTalk bus may require connections to the power supply from each end of the system ('ring-main' style), to maintain sufficient voltage throughout the system.

This requirement depends on the total length of the cable run and the total number of instruments in the system, as follows:

Cable run	No. of instruments	Power connections
Up to 10 m	13 maximum	1
	26 maximum	2
Up to 20 m	7 maximum	1
	13 maximum	2

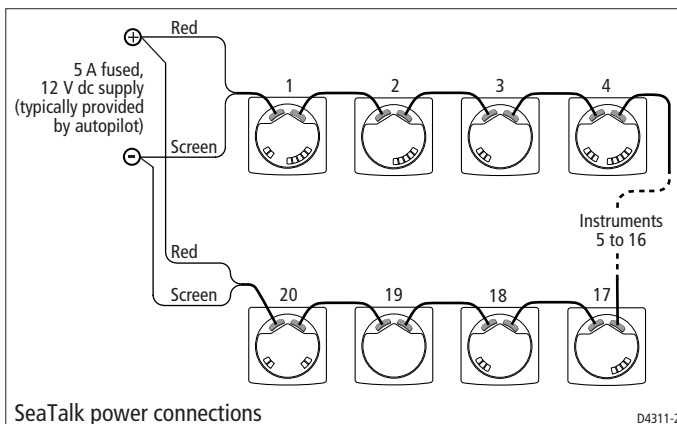

### Stand alone instruments

Stand-alone instruments are not connected to SeaTalk and therefore need to be connected to an alternative 12 V power source. Power cables are available in 2 m and 9 m lengths.

To fit a power cable:

1. Ensure the intended power source is switched off. If you are using a 12 V battery, ensure the power cable is not connected to the battery.
2. Run the power cable from the instrument to a suitable 12 V dc power source.
3. If the cable has not already been trimmed at the power supply end:
4. Cut the cable to length and trim back an appropriate amount of the outer sheath.
5. Cut back and insulate the yellow wire.
6. Connect the screen to the power supply 0 V terminal.

7. Connect the red wire via a 3 A over-current circuit breaker to the power supply +12 V terminal.

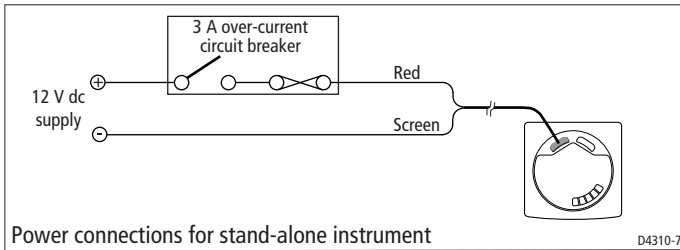

# Chapter 4: Calibration

## 4.1 Introduction

The ST60 Speed instrument is set up with factory-programmed default settings, so in order to optimise the performance of the instrument on board a particular vessel, the procedures in this Chapter must be carried out immediately after the completion of installation, and before the equipment is used for navigational purposes.

Where practicable, the calibration procedures are presented diagrammatically to show the sequence of key presses and the resulting displays. Adjustment instructions are given where applicable.

### EMC conformance

Always check the installation before going to sea to make sure that it is not affected by radio transmissions, engine starting etc.

### Speed readings

One of the most important reasons for calibrating the ST60 Speed instrument is to ensure that speed readings displayed on the instrument are a true reflection of the actual speed of the vessel.

In *User calibration*, you can:

- Automatically set the displayed speed reading to be the same as the Speed Over Ground (SOG) (if SOG data is available).
- Manually apply a calibration factor, to set the displayed speed to the required value.

If neither of the above methods are suitable, you can carry out a speed calibration run over a measured distance, to enable the instrument to calculate the correct calibration factor. This is described as part of *Intermediate calibration*.

## 4.2 User calibration

The User calibration procedures enable you to:

- Set the required units for speed readings.
- Set the required Log units.
- Set the speed resolution.
- Manually apply a calibration factor or auto-adjust to Speed Over Ground (SOG), to obtain correct speed through the water.
- Select temperature units.
- Calibrate for correct temperature readings.
- Set timer buzzer on or off.
- Set pop-up pilot display on or off.

### Procedure

To carry out a User calibration:

1. Power up the ST60 Speed instrument.
2. Press the **speed** and **trip** keys for approximately 2 seconds so that the User calibration entry screen is displayed.
3. Referring to the *User calibration* diagram, carry out the calibration procedure. Use the **speed** key to cycle from screen to screen and the **timer** and **reset** keys to set the required values (except Adjust to SOG display).

#### Set speed units

Select either KTS (knots), MPH (miles per hour) or KMH (kilometres per hour), as required.

#### Set resolution

Select resolution of either 0.01 or 0.1 as required.

#### Set log units

Select either NM (nautical miles), SM (statute miles) or KM (kilometres), as required.

#### Setting the correct speed

Set the displayed (current) speed using one of the following methods:



- Use the Adjust to SOG screen to automatically set the current speed to SOG (if available from SeaTalk). You must be running in slack tide conditions to successfully use this method.
- Manually apply a calibration factor by means of the Cal factor adjust screen, to set the displayed speed value to your best estimate of the vessel's speed.

### **Adjust to SOG**

The Adjust to SOG screen is displayed only if SOG data is available from SeaTalk. The current SOG is displayed in the top right of the display (12.8 in the illustration), and the current speed registered by the instrument is shown as large figures (12.4 in the illustration).

It is recommended that, if you are running in slack tide conditions, you press the **reset** key for 3 seconds, to accept the SOG as the current speed. The calibration factor is automatically re-calculated.

If you do not wish to accept SOG as the current speed, press the **timer** and **reset** keys together to select the Cal factor adjust screen.

### **Cal factor adjust**

The Cal factor adjust screen enables you to manually adjust the calibration factor. It shows the current calibration factor in the top right of the display, and the current speed as large figures (12.4 in the illustration).

Use the **timer** or **reset** key to adjust the calibration factor so that the current speed is the speed through the water.

If SOG data is available from SeaTalk, you can turn to the Adjust to SOG screen by pressing the **timer** and **reset** keys.

**Note:** *If neither of the above methods gives satisfactory results, carry out the Speed calibration procedure (part of Intermediate calibration).*

### **Set temperature units**

Select either °C or °F, as required.

### **Temperature calibration**

Set the display to show the current water temperature.

### **Timer buzzer**

Switches the count-up and race-start timer buzzers on and off.

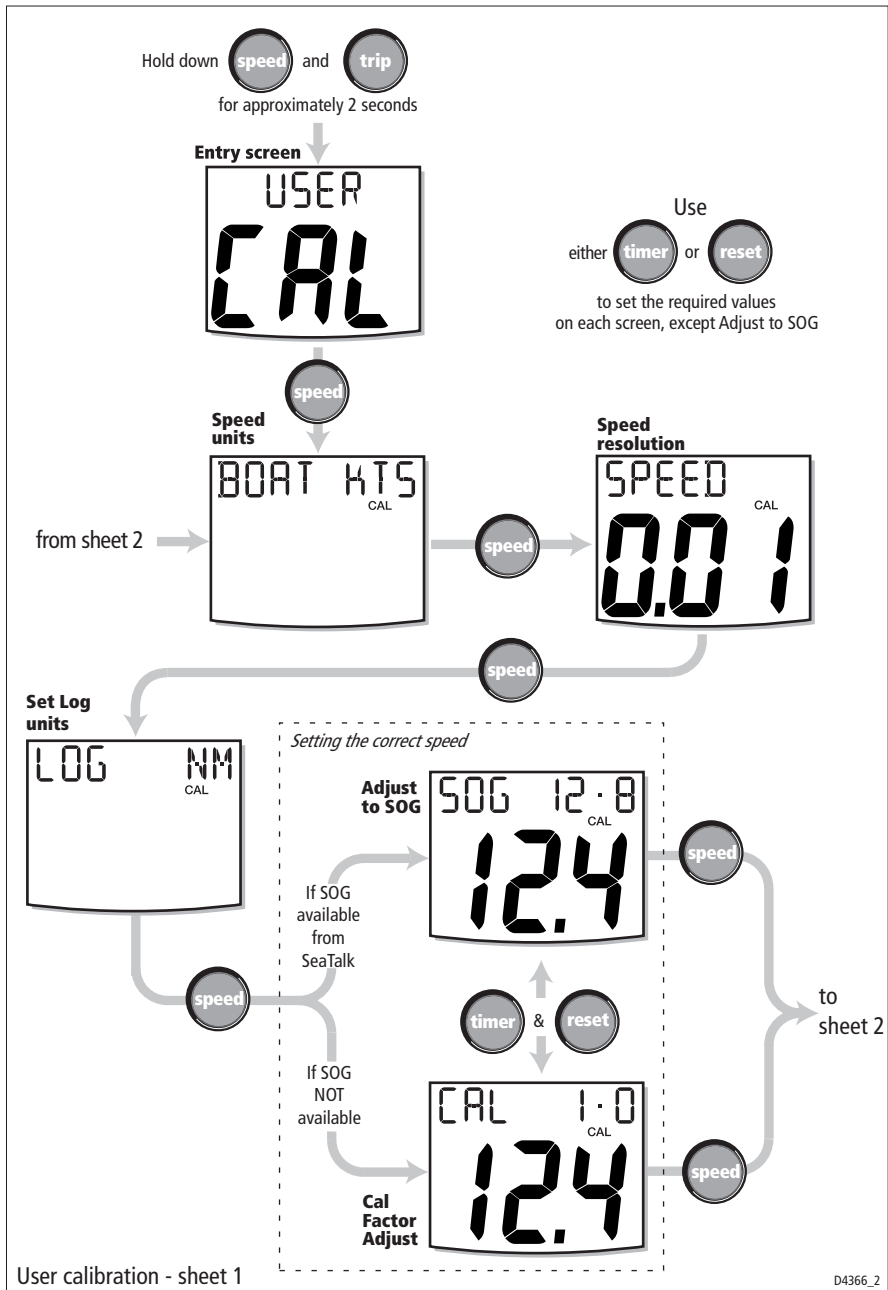

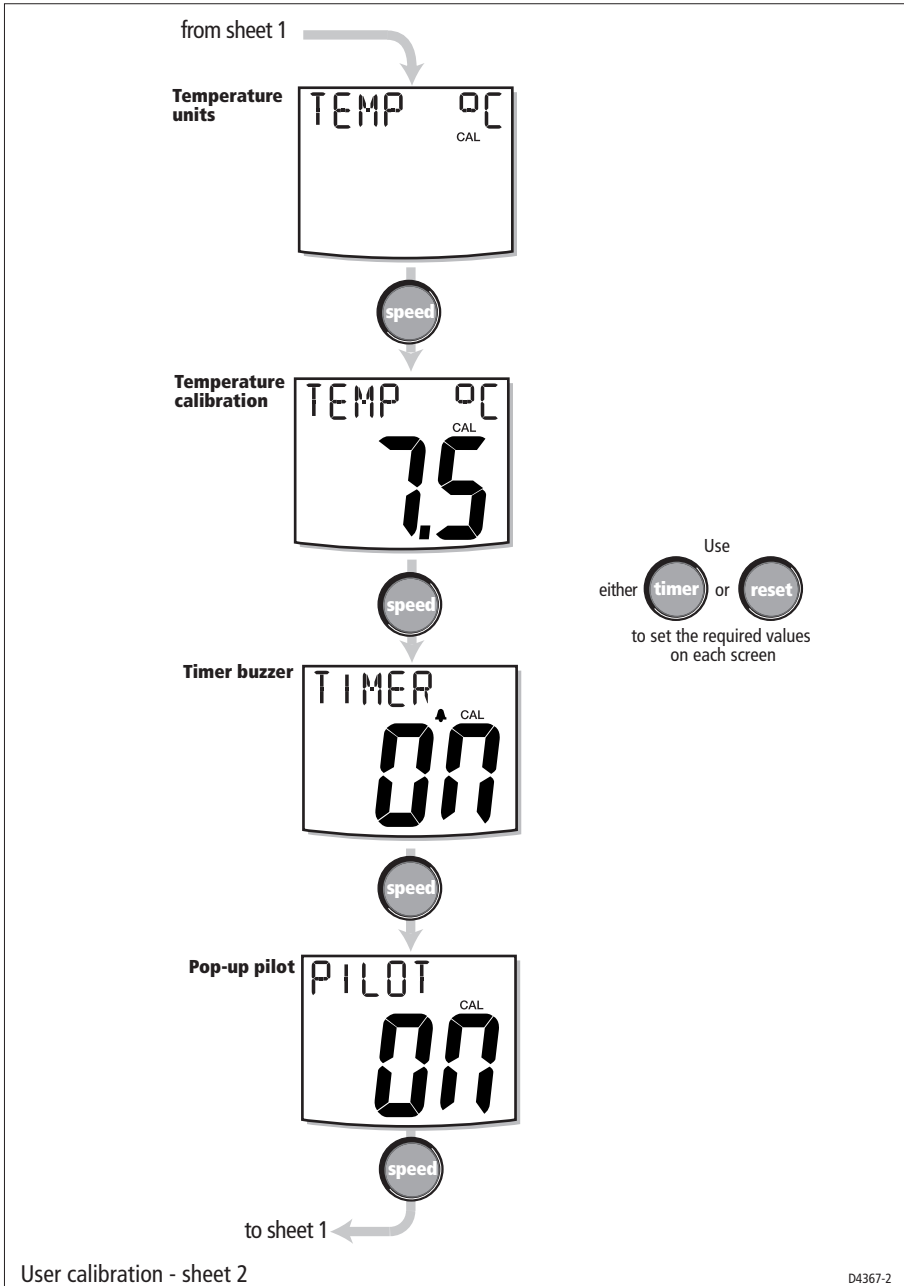

### Pop-up pilot

Switches the pop-up pilot function on and off.

### Leaving User calibration

Hold down the **speed** and **trip** keys for 2 seconds to save your settings, exit User calibration and resume normal operation.

## 4.3 Intermediate calibration

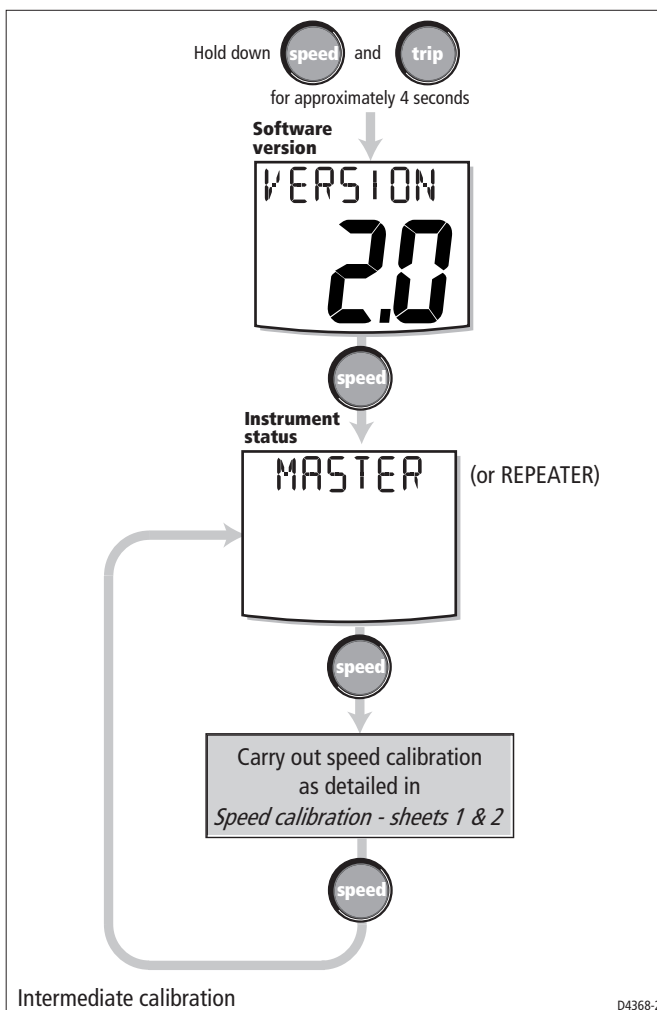

Intermediate calibration enables you to:

- Check the instrument software version.
- Check the instrument status - either MASTER (transducer connected) or REPEATER (no transducer).
- Carry out a calibration run over a measured distance to ensure accurate speed readings.

To start Intermediate calibration, hold down the **speed** and **trip** keys for approximately 4 seconds (see *Intermediate calibration* flow chart).

## Speed calibration

The speed calibration procedure involves carrying out two runs over a measured distance, to enable a calibration factor to be determined and applied to your ST60 Speed instrument, to ensure optimum accuracy. Each calibration run comprises outward and return legs, to minimise the affect of tidal drift when the calibration factor is determined.

To carry out a speed calibration, start the Intermediate calibration procedure and use the **speed** key to proceed to the Calibration run length screen (see *sheet 1* of the *Speed calibration* flow chart). Proceed with the speed calibration as follows:

1. With the Calibration Run Length screen displayed, press the **timer** and **reset** keys together to enter adjust mode. In this mode, the displayed run length flashes on and off.
2. Set the length of the intended calibration run, using either the **timer** key to decrement or the **reset** key to increment the run length value. You can set any value between 0.25 and 2.50.
3. Press **timer** and **reset** keys together to commence the speed calibration. The Cal status screen is displayed. The text at the top of the screen alternates between START 1 and the calibration factor currently applied.
4. Start first outward leg of the calibration run and as you pass the start point, press the **trip** key, so the screen shows OUTWARD at the top. As the calibration run proceeds, the displayed value will increment.
5. At the end of the outward leg, press the **trip** key again so that:
  - The text RETURN is flashing at the top of the screen.
  - The displayed distance freezes. Note that this value will not be the same as the measured distance due to errors introduced by tidal flow.

- Turn the vessel round, start the return leg and as you do so, press the **trip** key so RETURN stops flashing and the displayed value increments.

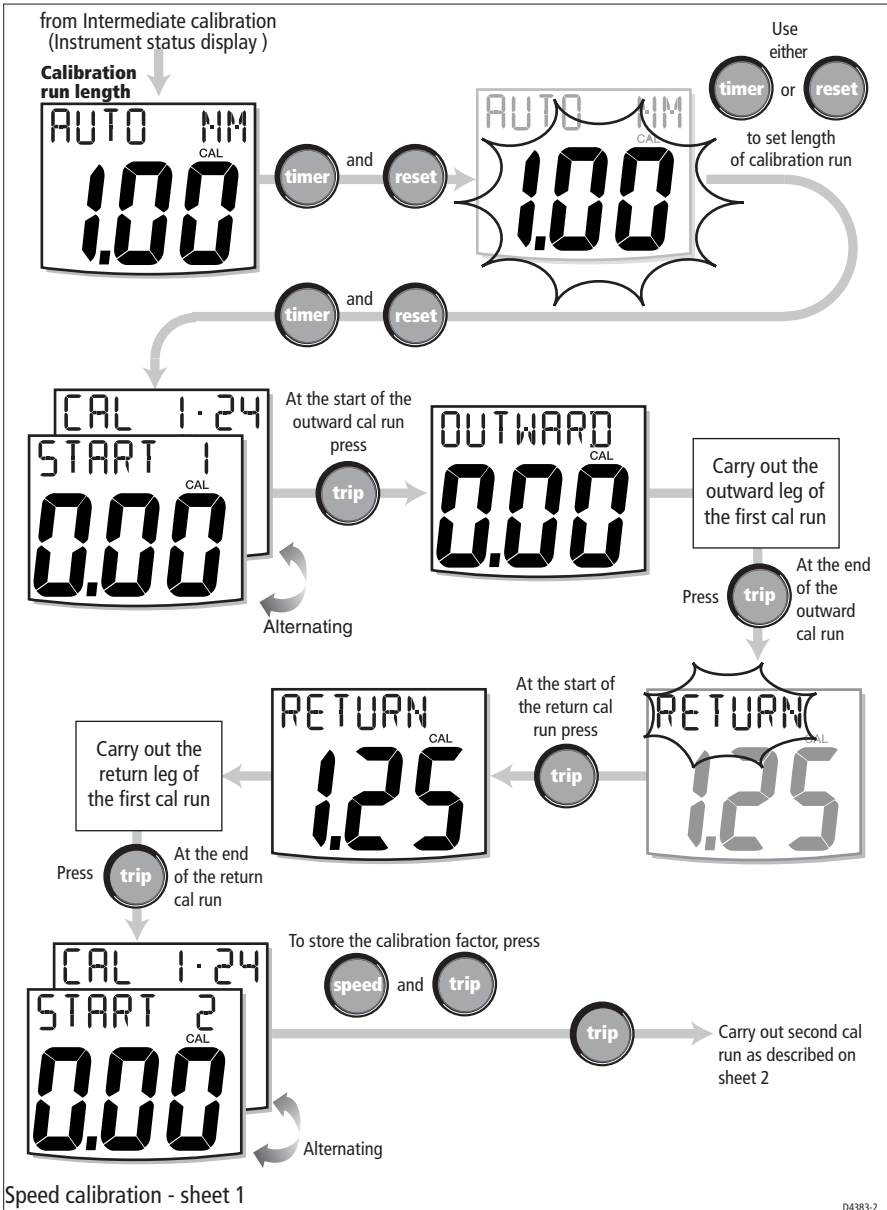

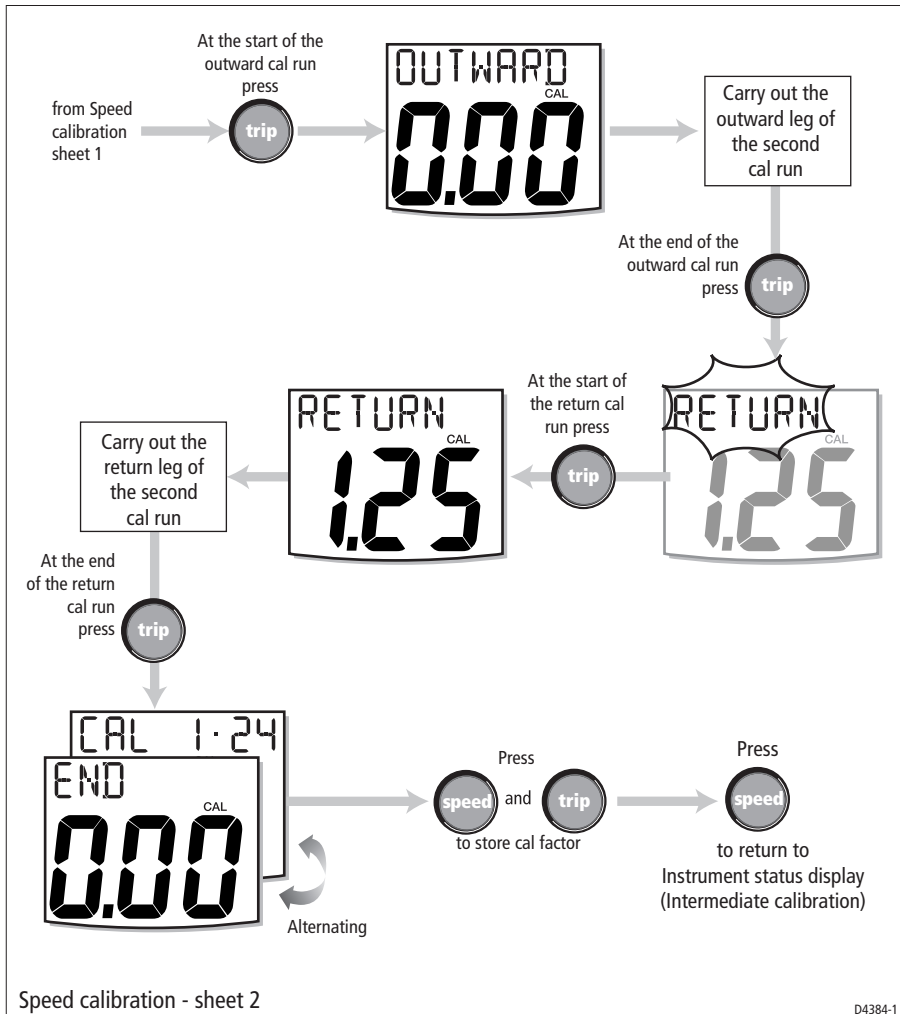

7. At the end of the return leg, press the **trip** key to end the calibration run. At this point:
  - The text START 2 alternating with the new calibration factor is displayed at the top of the screen.
  - The displayed distance freezes. This value should be very close to the actual (measured) distance of the calibration run.
8. Press the **speed** and **trip** keys together, to store the new calibration factor.

9. Carry out a second calibration run (see *sheet 2* of the *Speed calibration* flow chart), using the procedure described above in steps 4 to 8.

**Note:** *At the end of this second run, the text END alternating with the new calibration factor is displayed at the top of the screen.*

10. Press the **speed** key to leave speed calibration and return to the Instrument status screen.

## Leaving Intermediate calibration

Hold down the **speed** and **trip** keys for 2 seconds to save your settings, exit Intermediate calibration and resume normal operation.

## 4.4 Dealer calibration

The Dealer calibration procedure (see *Dealer calibration* diagram) enables the following parameters to be set:

- User calibration on/off.
- Speed response.
- VMG response.
- Boat show mode on/off.

Dealer calibration also gives access to the Factory defaults screen. This enables you to re-apply the factory settings if you want to reset the instrument to a known operating condition.

To commence Dealer calibration, hold down the **speed** and **trip** keys together for approximately 12 seconds, to select the Dealer calibration entry page. Press the **timer** and **reset** keys together, to proceed with the calibration, then use the **speed** key to proceed from screen to screen as calibration progresses.

### User calibration on/off

Press the **timer** or **reset** keys to toggle the User calibration either ON or OFF as required. With OFF selected, User calibration and Intermediate calibration are both disabled.



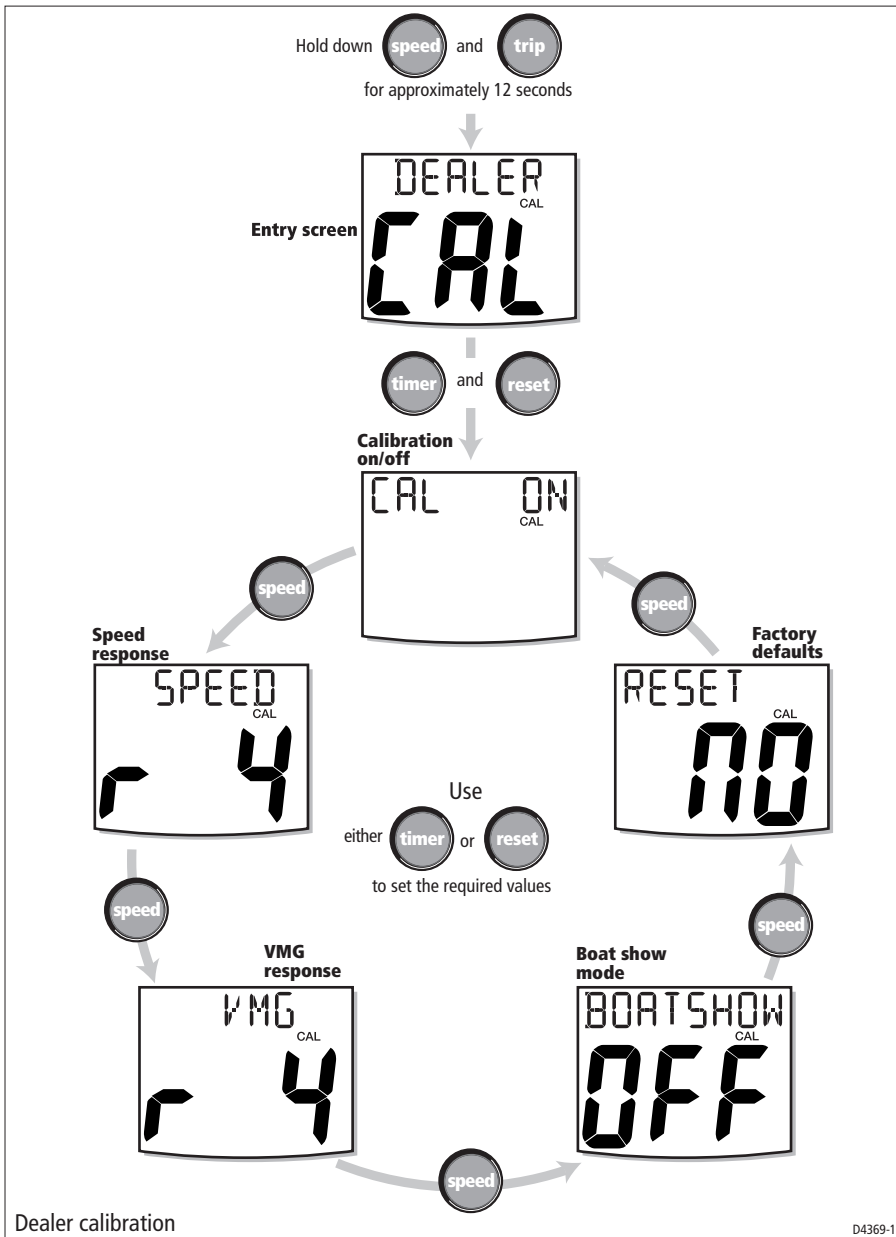

## Response settings

The response values for both SPEED and VMG determine the frequency at which information is updated. A low number provides a smooth response and a high number a much livelier update.

Use the **timer** (decrement) and **reset** (increment) keys to set the required value. Response values are from 1 to 15.

## Boat show mode

### **CAUTION:**

**Do NOT enable this mode. It must only be used for demonstration purposes.**

Ensure that the Boatshow Mode Use is set to OFF. If necessary, use the **timer** or **reset** key to achieve this.

## Factory defaults

You can use this screen to reset the operating parameters to the factory default values. Use the **timer** and **reset** keys to make the required selection.

Note that the selection you make at this screen will be applied when you exit the screen, so be sure you make the correct selection.

If you want to apply the factory defaults, ensure the display shows YES, but **if you want to retain the current values, ensure that the display shows NO.**

## Leaving Dealer calibration

Hold down the **speed** and **trip** keys for 2 seconds to save your settings, exit Dealer calibration and resume normal operation.

